



YX9000 Series High Performance Vector Converter

YX9000系列产品为高性能矢量型变频器的主力产品。秉承源信电气对产品高品质、高可靠性的一贯追求，客户通用需求与客户个性化需求、行业性需求进行了有机结合。

PRODUCT POWER
Single-phase/three-phase input, three-phase output
220V (+20%) 0.4KW-2.2KW
380V (+20%) 0.75KW-1000KW



The YX9000 series products are the main products of Yuanxin Electric's high-performance vector frequency converters. Adhering to the consistent pursuit of high quality and reliability of products by Yuanxin Electric, we have organically combined the general needs of customers with their personalized and industry-specific needs.

Product characteristics

- ✦ Standard 485 communication port, supporting PG card expansion;
- ✦ Support backend software uploading and downloading, as well as monitoring driver parameters;
- ✦ With various protections and rich fault handling methods, protection measures can be selected based on the fault level;
- ✦ Equipped with the function of stacking primary and secondary frequency sources;
- ✦ Built in PID, 16 speed, swing frequency and other functions.



Technical specification

Project		Standard specification			
Input	Rated voltage/frequency	Single-phase 200V, 220V, three-phase 200V, 220V, 380V, 415V, 440V; 50Hz/60Hz			
	Allowable value of variable capacity	Voltage: -20% ~ +20%	Voltage unbalance rate: <3%	Frequency: ±5%	
Output	Rated voltage	0~200V/220V/380V/415V/440V			
	Frequency range	0Hz~3000Hz			
	Frequency Resolution	0.01Hz			
	Overload capacity	150% rated current for 1 minute, 180% rated current for 3 seconds			
Main control functions	Torque control accuracy	±5% (FVC)			
	Control mode	V/F, Speed sensorless vector control (SVC), Speed Sensorless Vector control (FVC)			
	Frequency accuracy	Digital setting: highest frequency × ± 0.01%; Analog setting: highest frequency × ± 0.2%			
	Frequency resolution	Digital setting: 0.01Hz; Analog setting: highest frequency × 0.1%			
	Starting frequency	0.40Hz~20.00Hz			
	Torque boost	Automatic torque increase, manual torque increase by 0.1%~30.0%			
	V/F curve	Five methods: constant torque V/F curve, one user-defined multi segment V/F curve method, and three torque reduction characteristic curve methods (2.0 power, 1.7 power, and 1.2 power)			
	Acceleration and deceleration curve	Two methods: linear acceleration and deceleration, S-curve acceleration and deceleration; Seven types of acceleration and deceleration times, with optional time units (minutes/second), up to 6000 minutes			
	Dc braking	DC braking frequency: 000Hz~maximum frequency; Braking time: 0.0s~36.0s; Braking action current value: 0.0%~100.0%			
	Energy consumption braking	Built in energy consumption braking unit (≤ 22KW), can be externally connected with braking resistor			
	Inching	Jog frequency range: 0.00Hz~50.00Hz; Jog acceleration and deceleration time: 0.0s~6500.0s			
	Built-in dual PID	Can easily form a closed-loop control system			
	Instant stop	During an instantaneous power outage, the reduction in voltage is compensated through load feedback energy to maintain the operation of the variable frequency drive for a short period of time			
	Multi-speed operation	Up to 16 segments of speed operation can be achieved through built-in PLC or control terminals			
	Textile swing	Can achieve preset frequency and adjustable center frequency swing function			
	Automatic Voltage Regulation (AVR)	When the grid voltage changes, maintain a constant output voltage			
	Automatic energy-saving operation	Automatically optimize the V/F curve based on load conditions to achieve energy-saving operation			
	Automatic current limiting	Automatically limit the current during operation to prevent frequent overcurrent faults from tripping			
	Multi-pump constant pressure water supply control function	Connected to the water supply control board, it can achieve multi pump constant pressure water supply control function			
	Communication function	Supports four types of fieldbuses: Modbus, Profibus, CANlink, and CANopen			
	Operation function	Run command channel	The operation panel is given; Control terminal setting; Serial port given; There are three ways to switch		
		Frequency setting channel	Keyboard simulation potentiometer setting; Keyboard ▲ and ▼ keys are given; Function code number given; Serial port given; Terminal UP/DOWN given; Analog voltage setting; Simulated current setting; Pulse setting; Combination given; Multiple given methods can be switched at any time		
		Switch input channel	Forward and reverse instructions; 8-channel programmable switch input, capable of setting 52 functions separately		
		Analog input channel	2 analog signal inputs, selectable from 4-20mA and 0-10V		
		Analog output channel	Analog signal output, selectable from 4-20mA or 0-10V, capable of outputting physical quantities such as set frequency and output frequency		
	Operation panel	Switch, pulse output channel	2 programmable open collector outputs; Two relay output signals; 1 channel of 0-20KHz pulse output signal, achieving various physical quantity outputs		
LED digital display		Can display parameters such as set frequency, output voltage, output current, etc			
External instrument display		Display of physical quantities such as output frequency, output current, and output voltage			
Protection function	Key lock	Implement full lock of buttons			
	Protection function	Overcurrent protection; Overvoltage protection; Under voltage protection; Overheat protection; Overload protection; Phase loss protection (when>2.2KW), etc			
Option	Option	Brake components; Remote operation panel; Remote cable; Keyboard mounting base, etc			
	Environment	Place of use	Indoor, free from direct sunlight, dust, corrosive gases, oil mist, water vapor, etc		
		Altitude	Below 1000 meters (derated for use above 1000 meters)		
		Ambient temperature	-10°C~+40°C		
		Humidity	Less than 95% RH, no condensation		
		Vibrate	Less than 5.9m/s ² (0.6M)		
Storage temperature	-20°C~+60°C				
structure	Protection grade	IP20 (when selecting a status display unit or keyboard)			
	Cooling method	Forced air cooling			
Installation method	Wall mounted, cabinet mounted				

Basic parameters

Model		Rated capacity (KVA)	Rated output current (A)	Adaptive motor power (KW)
General	Fan and water pump type			
Single phase power supply: 220V, 50/60Hz				
YX9000-2S0004G	-----	1.0	3	0.4
YX9000-2S0007G	-----	1.5	4	0.75
YX9000-2S0015G	-----	2.8	7	1.5
YX9000-2S0022G	-----	3.8	9.6	2.2
Three phase power supply: 220V, 50/60Hz				
YX9000-2T0015G	-----	3.0	5.1	1.5
YX9000-2T0022G	-----	4.0	9	2.2
Three phase power supply: 380V, 50/60Hz				
YX9000-4T0007G	YX9000-4T0015P	1.5	2.1	0.75
YX9000-4T0015G	YX9000-4T0022P	2.2	3.8	1.5
YX9000-4T0022G	YX9000-4T0037P	3.0	5.1	2.2
YX9000-4T0037G	YX9000-4T0055P	5.9	9	3.7
YX9000-4T0055G	YX9000-4T0075P	8.5	13	5.5
YX9000-4T0075G	YX9000-4T0110P	11	17	7.5
YX9000-4T0110G	YX9000-4T0150P	17	25	11
YX9000-4T0150G	YX9000-4T0185P	21.7	32	15
YX9000-4T0185G	YX9000-4T0220P	25.7	37	18.5
YX9000-4T0220G	YX9000-4T0300P	29.6	45	22
YX9000-4T0300G	YX9000-4T0370P	39.5	60	30
YX9000-4T0370G	YX9000-4T0450P	49.4	75	37
YX9000-4T0450G	YX9000-4T0550P	60	90	45
YX9000-4T0550G	YX9000-4T0750P	73.7	110	55
YX9000-4T0750G	YX9000-4T0900P	99	152	75
YX9000-4T0900G	YX9000-4T1100P	116	176	90
YX9000-4T1100G	YX9000-4T1320P	138	210	110
YX9000-4T1320G	YX9000-4T1600P	167	253	132
YX9000-4T1600G	YX9000-4T1850P	200	304	160
YX9000-4T1850G	YX9000-4T2000P	234	355	185
YX9000-4T2000G	YX9000-4T2200P	248	380	200
YX9000-4T2200G	YX9000-4T2500P	280	426	220
YX9000-4T2500G	YX9000-4T2800P	318	465	250
YX9000-4T2800G	YX9000-4T3150P	342	520	280
YX9000-4T3150G	YX9000-4T3500P	390	585	315
YX9000-4T3500G	YX9000-4T4000P	435	650	350
YX9000-4T4000G	YX9000-4T4500P	493	725	400
YX9000-4T4500G	YX9000-4T5000P	560	820	450
YX9000-4T5000G	YX9000-4T5600P	625	860	500
YX9000-4T5600G	YX9000-4T6300P	691	990	560
YX9000-4T6300G	YX9000-4T7100P	770	1100	630
YX9000-4T7100G	YX9000-4T8000P	880	1280	710
YX9000-4T8000G	YX9000-4T9000P	1030	1400	800
YX9000-4T9000G	YX9000-4T10000P	1120	1575	900
YX9000-4T10000G	YX9000-4T11000P	1250	1750	1000



Basic wiring diagram

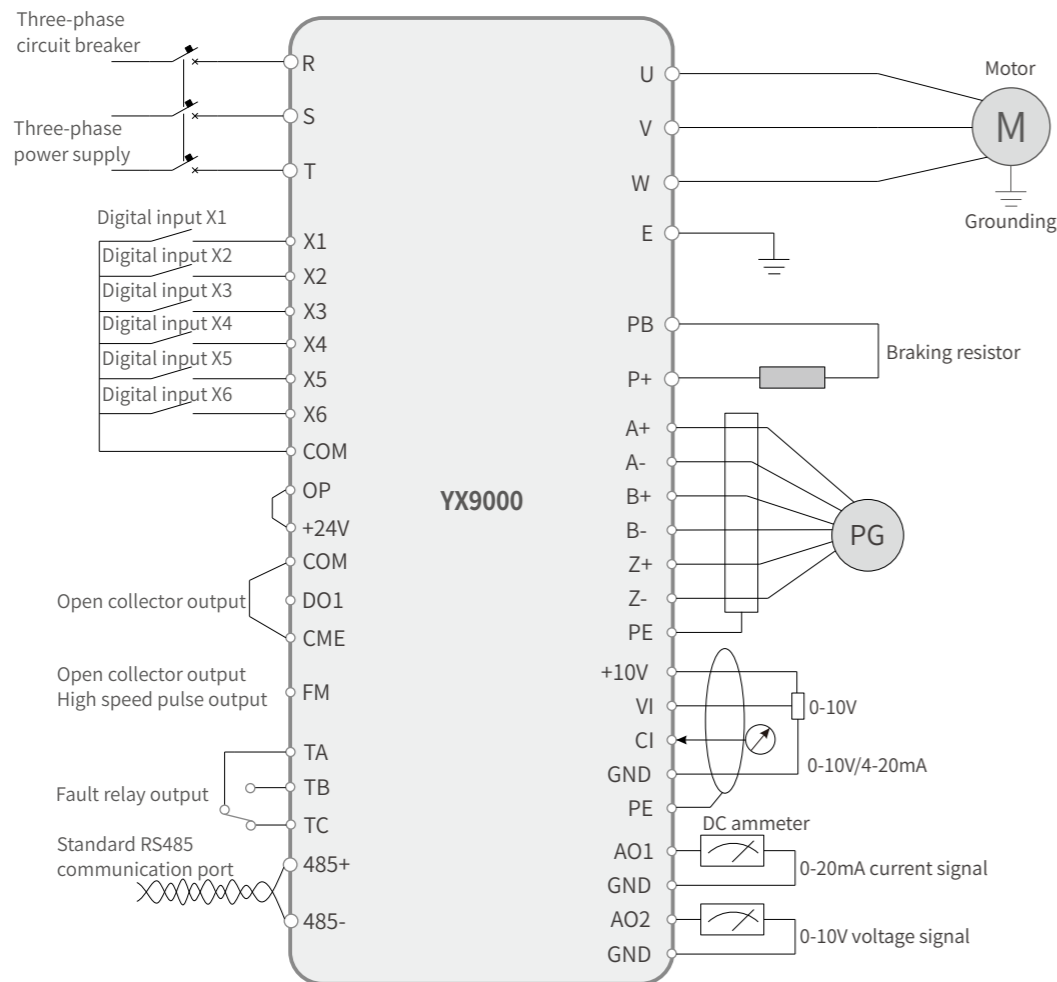

Control board terminals

1.5G~7.5G-M series

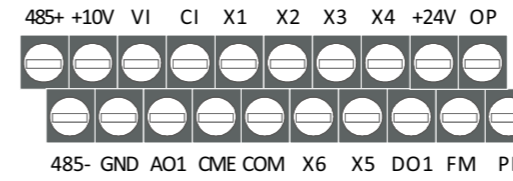

5.5G~1000G series

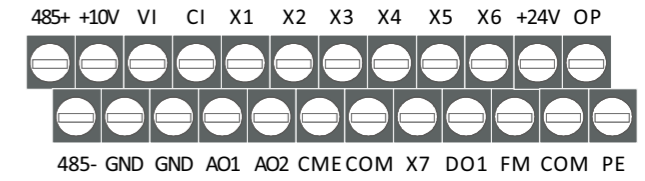

Category	Terminal identification	Name	Terminal Function Description	Specifications
Communicate	485+	Rs485 communication interface	Rs485 differential signal positive terminal	Standard RS485 communication interface, please use twisted pair or shielded wire
	485-		Rs485 differential signal negative terminal	
Digital Output	DO1-CME	Open collector output terminal 1	Optical isolation, bipolar open collector output; Note: The digital output ground CME is internally isolated from the digital input ground COM, but it is shorted to the COM through the JP1 jumper CME on the control board at the factory (at this time, DO1 defaults to +24V drive). When DO1 wants to be driven by an external power source, the JP1 jumper must be unplugged.	Optocoupler isolation output Output voltage range: 0V~24V Output current range: 0mA~50mA Please refer to P4.02 parameter description for usage methods
Pulse output terminal	FM-COM	Collector open circuit pulse output terminal	Programmable defined as a pulse output terminal with multiple functions, constrained by function code P4.06 (FM terminal input mode selection), when used as a collector open circuit switch output, it has the same specifications as DO1. (Common end: COM)	Output frequency range: determined by function code P4.09, maximum 100KHz
Analog input	VI	Analog input VI	Accept analog voltage input (Reference: GND)	Input voltage range: 0-10V (input impedance: 10K Ω); Resolution: 1/1000
	CI	Analog input CI	Accepts analog voltage/current input, with voltage and current selected by jumper CI and factory default voltage (Reference: GND)	Input voltage range: 0-10V (input impedance: 10K Ω) Input current range: 0-20mA (input impedance: 500 Ω) Resolution: 1/1000
Analog output	AO1	Analog output AO1	Provide analog voltage/current output, which can represent 7 quantities. The output voltage/current is selected by jumper AO1, and the factory default output voltage is provided. (Reference: GND)	Current output range: 4-20mA Voltage output range: 0-10V
	AO2	Analog output AO2	Provide analog voltage/current output, which can represent 7 quantities. The output voltage/current is selected by jumper AO2, and the factory default output voltage is provided. (Reference: GND)	Voltage output range: 0-10V
Multifunctional input terminals	X1	Multifunctional input terminal 1	Programmable input terminals are defined as multifunctional switch inputs, as detailed in Section 6.5 of Chapter 6, Introduction to Terminal Function Parameters (P3 Group) Input Terminal Functions. (Common end: COM)	Optocoupler isolation Compatible with bipolar inputs Input impedance: R=2K Ω Maximum input frequency: 200Hz Input voltage range 9-30V
	X2	Multifunctional input terminal 2		
	X3	Multifunctional input terminal 3		
	X4	Multifunctional input terminal 4		
	X5	Multifunctional input terminal 5		
	X6	Multifunctional input terminal 6		
Power supply	P24	+24V power supply	Provide +24V power supply externally. (Negative extreme: COM)	
	OP	External power input	Factory default and +24V external connection When using external signals to drive X1 to X6, the OP needs to be connected to an external power source and the short connector between OP and +24V needs to be unplugged	
	10V	+10V power supply	Provide external +10V power supply (Negative extreme: GND)	Maximum output current: 50mA
	GND	+10V power supply common terminal	Analog signal and reference ground for +10V power supply	Internal isolation between COM and GND
	COM	+24V power supply common terminal	Digital signal input, output common terminal	

Structural outline drawing

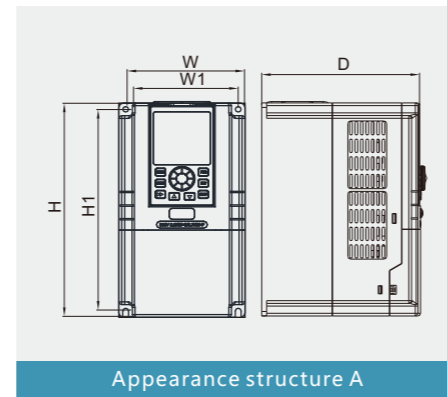
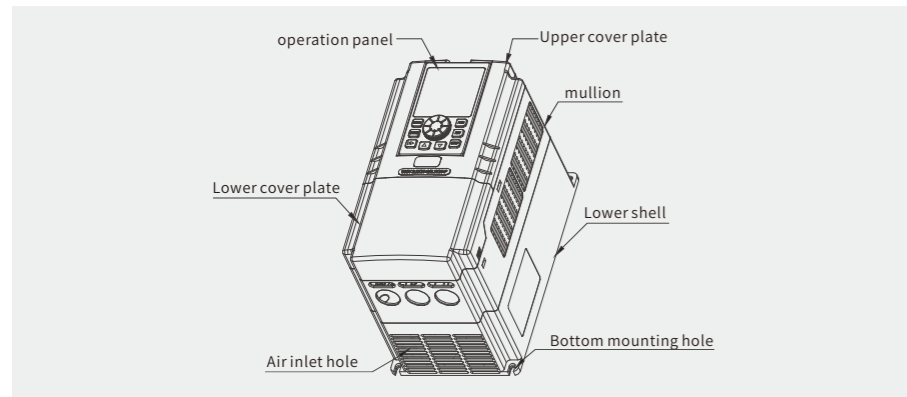

Appearance structure A

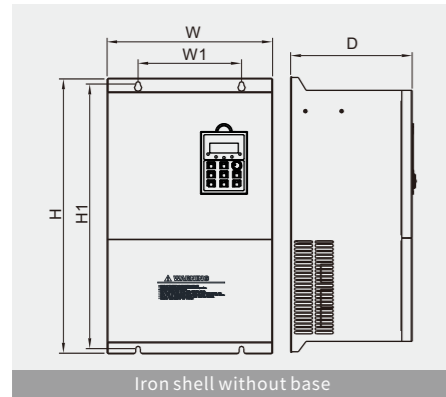

Iron shell without base

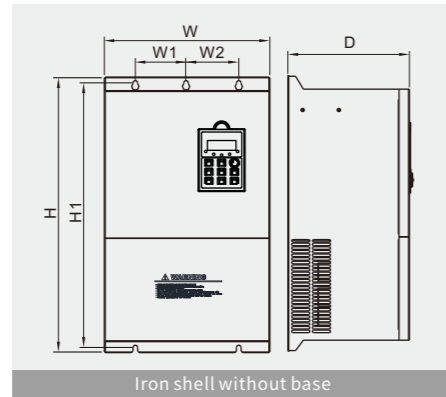

Iron shell without base

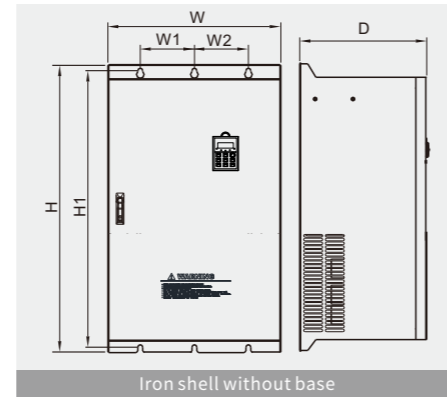

Iron shell without base

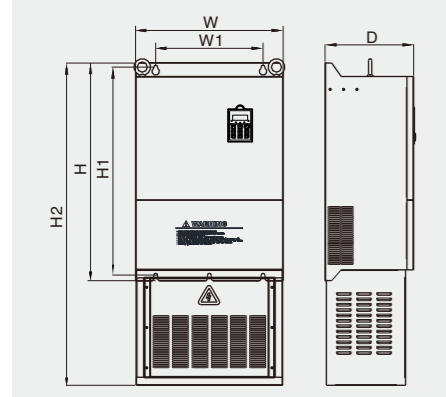

Iron shell with base
Appearance structure B

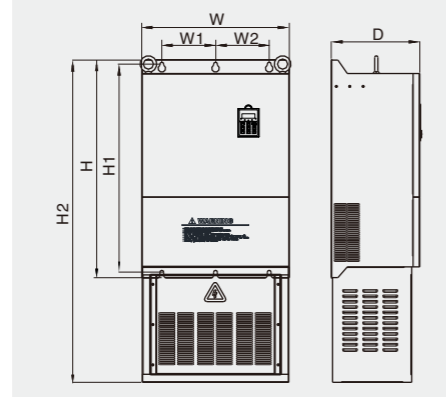

Iron shell with base
Appearance structure C

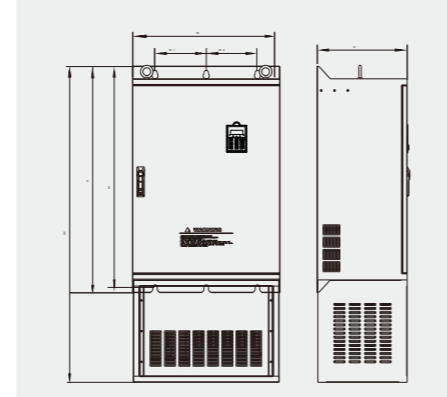

Iron shell with base
Appearance structure D

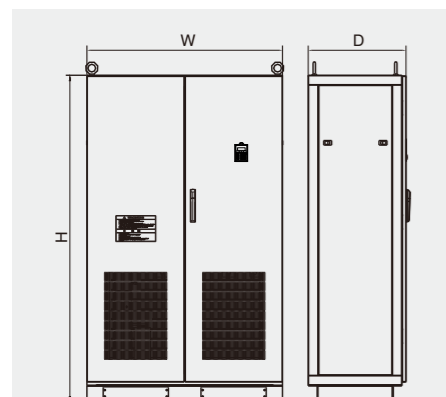

Appearance structure E



Structural dimension

Model		Overall dimensions (mm)				Installation size (mm)			Installation aperture	Outline structure
General	Fan and water pump type	H	W	D	H2	H1	W1	W2		
Single phase power supply: 220V, 50/60Hz										
YX9000-2S0004G	—	142	85	110	—	149.5	72.5	—	Φ5	A
YX9000-2S0007G	—									
YX9000-2S0015G	—									
Three phase power supply: 380V, 50/60Hz										
YX9000-4T0007G	YX9000-4T0015P	190	104	150	—	176	90	—	Φ5	A
YX9000-4T0015G	YX9000-4T0022P									
YX9000-4T0022G-M	—									
YX9000-4T0022G	YX9000-4T0037P	236	130	176	—	222	116	—	Φ6	A
YX9000-4T0037G	YX9000-4T0055P									
YX9000-4T0055G-M	—									
YX9000-4T0055G	YX9000-4T0075P	272	172	182	—	256	155	—	Φ7	A
YX9000-4T0075G	YX9000-4T0110P									
YX9000-4T0110G-M	—									
YX9000-4T0150G-M	—	330	200	200	—	316	188	—	Φ7	A
YX9000-4T0110G	YX9000-4T0150P									
YX9000-4T0150G	YX9000-4T0185P									
YX9000-4T0185G	YX9000-4T0220P	360	248	210	—	346	170	—	Φ7	B
YX9000-4T0220G	YX9000-4T0300P									
YX9000-4T0110G	YX9000-4T0150P									
YX9000-4T0150G	YX9000-4T0185P	445	260	230	—	426	200	—	Φ9	B
YX9000-4T0185G-M	—									
YX9000-4T0220G-M	—									
YX9000-4T0185G	YX9000-4T0220P	530	320	235	—	511	200	—	Φ9	B
YX9000-4T0220G	YX9000-4T0300P									
YX9000-4T0300G-M	—									
YX9000-4T0370G-M	—	555	310	260	—	530	250	—	Φ12	B
YX9000-4T0300G	YX9000-4T0370P									
YX9000-4T0370G	YX9000-4T0450P									
YX9000-4T0450G	YX9000-4T0550P	650	400	300	988	619.5	280	—	Φ14	B
YX9000-4T0550G	YX9000-4T0750P									
YX9000-4T0750G	YX9000-4T0900P									
YX9000-4T0900G	YX9000-4T1100P	760	390	320	1100	730	280	—	Φ14	B
YX9000-4T1100G	YX9000-4T1320P									
YX9000-4T1320G-M	—									
YX9000-4T1320G	YX9000-4T1600P	790	450	300	1130	755	280	—	Φ14	B
YX9000-4T1600G	YX9000-4T1850P									
YX9000-4T1850G	YX9000-4T2000P									
YX9000-4T2000G	YX9000-4T2200P	810	550	330	1200	775	200	200	Φ14	C
YX9000-4T2200G	YX9000-4T2500P									
YX9000-4T2500G	YX9000-4T2800P									
YX9000-4T2800G	YX9000-4T3150P	1102	720	440	1542	1047	250	250	Φ22	D
YX9000-4T3150G	YX9000-4T3500P									
YX9000-4T3500G	YX9000-4T4000P									
YX9000-4T4000G	YX9000-4T4500P	1270	820	400	1760	1220	300	300	Φ25	D
YX9000-4T4500G	YX9000-4T5000P									
YX9000-4T5000G	YX9000-4T5000P									
YX9000-4T5000G	YX9000-4T5600P	1900	950	475	—	—	—	—	Φ25	E
YX9000-4T5600G	YX9000-4T6300P									
YX9000-4T6300G	YX9000-4T7100P									
YX9000-4T7100G	YX9000-4T8000P	2000	1200	600	—	—	—	—	Φ25	E
YX9000-4T8000G	YX9000-4T9000P									
YX9000-4T9000G	YX9000-4T10000P									
YX9000-4T10000G	YX9000-4T11000P	2000	1500	600	—	—	—	—	Φ25	E